

FOREWORD

THANK YOU for choosing Suzuki. We at Suzuki have designed, tested and produced this motorcycle using the most modern technology available to provide you with many happy, enjoyable, safety riding. Motorcycling is one of man's most exhilarating sports and to insure your riding enjoyment, you should become thoroughly familiar with the information presented in this Owner's Manual before riding the motorcycle.

The proper care and maintenance that your motorcycle requires is outlined in this manual. By following these instructions explicitly you will insure a long trouble free operating life for your motorcycle. This motorcycle also conforms to the U.S. Environmental Protection Agency emission regulations which apply to new motorcycles. The proper adjustment of engine components is necessary for this motorcycle to comply with the EPA regulations. Therefore, please follow the maintenance instructions closely to ensure emission compliance. Your Suzuki dealer has experienced technicians that are trained to provide your machine with the best possible service with the right tools and equipment.

CAUTIONS TO GS450GA OWNERS

This motorcycle features the SUZUKIMATIC transmission, a torque converter coupled to a two-speed transmission for easy driving. The SUZUKIMATIC transmission and its related features require special care and operation which differs from standard shift motorcycles. Please follow the instructions below and thoroughly read the owner's manual for details.

STARTING THE ENGINE

- * Turn the ignition switch to the "C", check position, and pause before continuing to the "ON" position. In the "C" position the side stand position buzzer should buzz plus the side stand check light and oil pressure light will operate.
- * The engine will start in the neutral position only. For added safety, apply the parking brake. (The starter motor will not operate if the transmission is in gear.)
- * Warm up the engine until it idles smoothly without the choke. Starting off with the choke on can be dangerous since the motorcycle will start moving forward as soon as the gear is engaged and closing the throttle will not slow it down.

STARTING OFF

- * Engage the transmission when the engine is at idle speed only. If the gear is engaged with engine revved up, the motorcycle will abruptly move forward, possibly resulting in loss of rider control. It is a good practice to apply front brake when engaging the transmission.
- * Make sure that the parking brake is released before starting off. Driving with the parking brake engaged may damage the brake system and could affect rider control. The brake could actuate as soon as the throttle is closed, resulting in rear wheel lock.

DRIVING

- * The SUZUKIMATIC transmission provides less engine braking effect than a standard transmission. Do not rely on the engine to slow down motorcycle. Instead, carefully use the front and rear brakes. When driving down a steep hill at a relatively low speed, the engine brake effect can be increased by shifting the transmission to L range.
- * Do not down shift from D to L at normal driving speeds. The sudden increase in engine braking could cause loss of rider control.

WARNING:

While riding observe the instrument panel check lights. If the side stand check light comes on or the buzzer sounds, stop the motorcycle immediately. Inspect the position of the side stand and make sure it is firmly in the up position. If the light is on or the buzzer is sounding with the side stand firmly in the up position, have your Suzuki dealer effect repairs. We recommend that you have the motorcycle repaired continuing to operate it.

CAUTION:

If the oil pressure drops sufficiently to activate the oil pressure light, the side stand check light will also come on. Do not start the engine until the cause of the low oil pressure is found and cured.

STOPPING

- * For momentary stop such as waiting for traffic signals, you may leave the transmission in gear. But in such cases, apply the brakes firmly. Never use the throttle to hold on a hill since the torque converter "slippage" will create excessive heat and overheat the engine oil.
- * Use the parking brake when parking on a slight slope on the side stand to prevent the motorcycle from rolling off the side stand. The rear wheel can turn even when in gear with the engine not running.

OTHERS

- * Do not use A.T.F. (Automatic Transmission Fluid) in this motorcycle. If this oil is used, serious engine damage will result. See Fuel and Oil Recommendation section in this manual for proper engine oil selection.

TABLE OF CONTENTS

CONSUMER INFORMATION 2

 Accessory Installation and Precaution

 Safety Tips 2

 Vehicle Stopping Distance 4

 Safe Riding Recommendation for Motorcycle Riders 4

 Serial Number Location 4

LOCATION OF PARTS 5

CONTROLS..... 5

FUEL AND OIL RECOMMENDATION12

BREAK-IN12

INSPECTION BEFORE RIDING13

RIDING TIPS.....14

INSPECTION AND MAINTENANCE16

TROUBLESHOOTING34

STORAGE PROCEDURES34

SPECIFICATIONS.....37

WIRING DIAGRAM38

CONSUMER INFORMATION

ACCESSORY INSTALLATION AND PRECAUTION SAFETY TIPS

There are a great variety of accessories available to Suzuki owners. Suzuki can not have direct control over the quality or suitability of accessories you may wish to purchase. The addition of unsuitable accessories can lead to unsafe operating conditions. It is not possible for Suzuki to test each accessory on the market or combinations of all the available accessories; however, your dealer can assist you in selecting quality accessories and installing them correctly.

Use extreme caution when selecting and installing the accessories for your Suzuki. We have developed some general guidelines which will aid you when deciding whether, and how to equip your motorcycle.

- (1) Never exceed the GVWR (Gross Vehicle Weight Rating) of this motorcycle. The GVWR is the combined weight of the machine, accessories, payload and rider. When selecting your accessories, keep in mind the weight of the rider as well as the weight of the accessories. The additional weight of the accessories may not only create an unsafe riding condition but may also affect the steering ease.
GVWR—GS450GA: 860lbs (390 kg)
at the tire pressure (cold)
Front 24 psi (1.75 kg/cm²)
Rear 36 psi (2.50 kg/cm²)
 - (2) Anytime that additional weight or aerodynamic affecting accessories are installed, they should be mounted as low as possible as close to the motorcycle and as near the center of gravity as is feasible. The mounting brackets and other attachment hardware should be carefully checked to ensure that it provides for a rigid, non-moveable mount. Weak mounts can allow the shifting of the weight and create a dangerous, unstable condition.
 - (3) Inspect for proper ground clearance and bank angle. An improperly mounted load could critically reduce these two safety factors. Also determine that the "load" does not interfere with the operation of the suspension, steering or other control operations.
 - (4) Accessories fitted to the handlebars or the front fork area can create serious stability problems. This extra weight will cause the motorcycle to be less responsive to your steering control. The weight may also cause oscillations in the front end and lead to instability problems. Accessories added to the handlebar or front fork of the machine should be as light as possible and kept to a minimum.
 - (5) Windshields, fairings, backrests, saddlebags, travel trunks, etc., may affect the stability of the motorcycle due to their aerodynamic effects. The motorcycle may be affected by a lifting condition or by an instability in cross winds or when being passed or passing large vehicles. Improperly mounted or poorly designed accessories can result in an unsafe riding condition, therefore caution should be used when selecting and installing all accessories.
 - (6) Certain accessories displace the rider from his normal riding position. This limits the freedom of movement of the rider and may limit his control ability.
 - (7) Additional electrical accessories may overload the existing electrical system. Severe overloads may damage the wiring harness or create a dangerous situation due to the loss of electrical power during the operation of the motorcycle.
- When carrying a load on the motorcycle, mount it as low as possible and as close as possible to the machine. An improperly mounted load can create a high center of gravity which is very dangerous and makes the motorcycle difficult to handle. The size of the "load" can also affect the aerodynamics and handling of the motorcycle. Balance the load between the left and right side of the motorcycle and fasten it securely.

MODIFICATION

Modification of the motorcycle, or removal of original equipment may render the vehicle unsafe or illegal. Obey all applicable equipment regulations in your area.

VEHICLE STOPPING DISTANCE

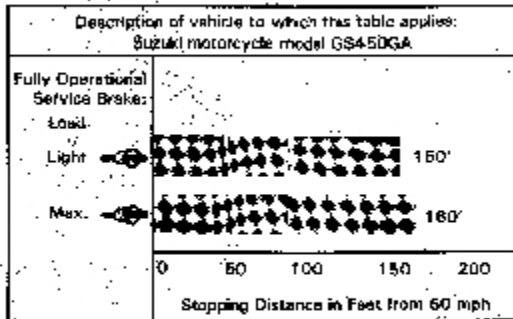

This figure indicates braking performance that can be met or exceeded by the vehicle to which it applies under different conditions of loading.

The information presented represents results obtainable by skilled drivers under controlled road and vehicle conditions, and the information may not be correct under other conditions.

SAFE RIDING RECOMMENDATION FOR MOTORCYCLE RIDERS

Motorcycle riding is great fun and an exciting sport. Motorcycle riding also requires that some extra precautions be taken to ensure the safety of the rider and passenger. These precautions are:

WEAR A HELMET

Motorcycle safety equipment starts with a quality safety helmet. One of the most serious injuries that can happen is a head injury. ALWAYS wear a properly approved helmet. You should also wear suitable eye protection.

RIDING APPAREL

Loose fancy clothing can be uncomfortable and unsafe when riding your motorcycle. Choose good quality motorcycle riding apparel when riding your motorcycle.

INSPECTION BEFORE RIDING

Review thoroughly the instructions in the "INSPECTION BEFORE RIDING" section of this manual. Do not forget to perform an entire safety inspection to ensure the safety of the rider and its passenger.

FAMILIARIZE YOURSELF WITH THE MOTORCYCLE

Your riding skill and your mechanical knowledge form the foundation for safe riding practices. We suggest that you practice riding your motorcycle in a non-traffic area. Frame number Engine number with your machine and its controls. Remember practice makes perfect.

KNOW YOUR LIMITS

Ride within the boundaries of your own skill at all times. Knowing these limits and staying within them will help you to avoid accidents.

BE EXTRA SAFETY CONSCIOUS ON BAD WEATHER DAYS

Riding on bad weather days, especially wet ones, requires extra caution. Braking distances double on a rainy day. Stay off of the painted surface marks, manhole covers and greasy appearing areas as they can be especially slippery. Use extreme caution at railway crossings and on metal gratings and bridges. Whenever in doubt about road conditions, slow down!

SERIAL NUMBER LOCATION

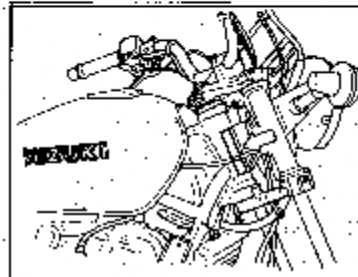

Frame number



Engine number

The frame and/or engine serial numbers are used to register the motorcycle. They are also used to assist your dealer when ordering parts or referring to special service information.

The frame number is stamped on the steering head tube. The engine serial number is stamped on the left right of the crankcase assembly.

Please write down the numbers here for your reference.

Frame No. _____

Engine No. _____

LOCATION OF PARTS

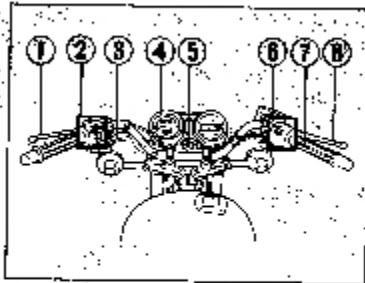

- (1) Parking brake lever
- (2) Left handlebar switch
- (3) Carburetor choke lever
- (4) Speedometer
- (5) Ignition switch
- (6) Right handlebar switch
- (7) Throttle grip
- (8) Front brake lever

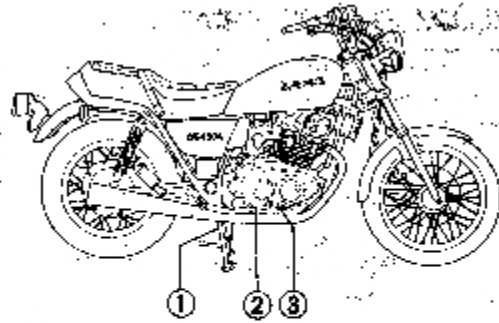

- (1) Center stand
- (2) Rear brake pedal
- (3) Engine oil inspection window

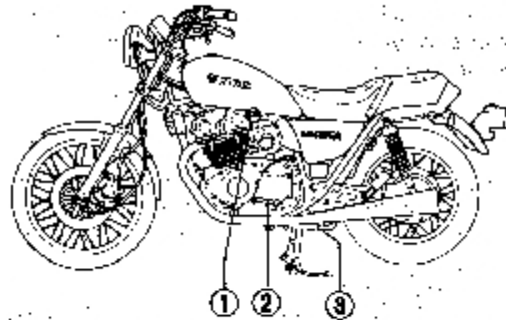

- (1) Fuelcock
- (2) Gear shift lever
- (3) Side stand

CONTROLS

KEY

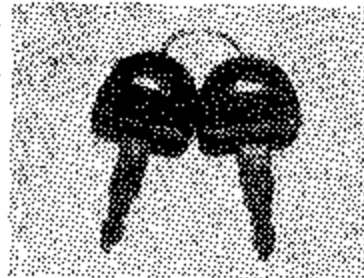

This motorcycle comes equipped with a pair of identical ignition keys. Keep the spare key in a safe place.

Your motorcycle ignition keys are stamped with an identifying number. This number is used when making replacement keys. Please write your key number in the box provided for your future reference.

KEY NO.: _____

IGNITION SWITCH

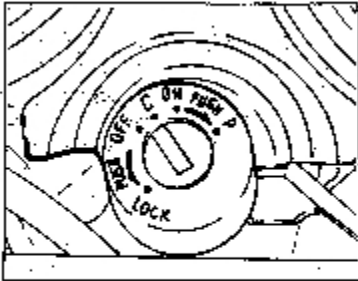

The ignition switch has five positions:

"OFF" POSITION

All electrical circuits are cut off.

"C" POSITION

This position is located between the "OFF" and "ON" positions without any click or detent to hold it on. Check the side stand buzzer in this position for operation. The buzzer continues to sound until the "ON" position is reached.

WARNING:

If the side stand buzzer does not operate in the "C" position, have your Suzuki dealer effect repairs. We strongly recommend that the motorcycle be repaired before operating.

"ON" POSITION

The ignition circuit is completed and the engine can now be started. The headlight and taillight will automatically be turned on when the switch is in this position. The key cannot be removed from the ignition switch in this position. Check the oil pressure and side stand check light indicator lights in the instrument panel with the ignition switch in "ON" position before starting the engine. These lights should come on to indicate the bulbs are functioning properly.

CAUTION:

Start the engine promptly after turning the ignition switch to the "ON" position. The reason for this is that the headlight and taillight come on at the same time the ignition is turned on and will cause the battery to lose power.

"PARKING" POSITION ("P" POSITION)

When parking the motorcycle, turn the handlebar all the way to the right or to the left. Push down and turn the key to the parking position. The key can now be removed and the taillight will remain lit and the steering will be locked. This position is for night time roadside parking to increase visibility.

"LOCK" POSITION

To lock the steering, turn the handlebar all the way to the right or the left. Push down and turn the key to the "LOCK" position and remove the key. All electrical circuits are cut off.

WARNING:

Before turning the ignition switch to the (P) "PARK" or "LOCK" position, stop the motorcycle and place the motorcycle on either the side stand or the center stand.

INSTRUMENT PANEL

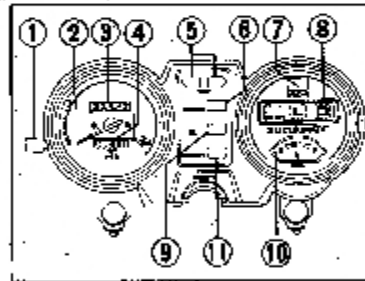

SPEEDOMETER (2)

The speedometer indicates the road speed in miles per hour and kilometers per hour.

ODOMETER (3)

The odometer registers the total distance that the motorcycle has been ridden.

TRIP METER (4)

The trip meter is a resettable odometer located in the speedometer assembly. It can be used to indicate the distance traveled on short trips or between fuel stops. Turning the knob (1) counter-clockwise will return the meter to zero.

TURN SIGNAL INDICATOR LIGHT (5)

When the turn signals are being operated either to the right or left side, the amber indicator light will flash.

HIGH BEAM INDICATOR LIGHT (6)

The blue indicator light will be lit when the headlight high beam is turned on.

PARKING BRAKE INDICATOR LIGHT (7)

The parking brake indicator light will be lit when the parking brake is in engaged position.

GEAR POSITION INDICATOR LIGHTS (8)

The green light will come on when the transmission is in neutral. The light will be go out when you shift into any gear other than neutral.

L:

The letter "L" in this indicator shows the gear is in LOW range.

D:

The letter "D" in this indicator shows the gear is in DRIVE range.

OIL PRESSURE INDICATOR LIGHT (9)

With the ignition switch in the "ON" position but the engine not started, the oil pressure indicator light should be lit. As soon as the engine is started, the light should go out.

CAUTION:

Whenever the oil pressure indicator lights up, indicating no oil pressure, stop the engine immediately. First check the oil level and determine if the proper amount of oil is in the engine. If the oil level is low, refill the engine to the correct level. If the light still does not go out, then have your authorized Suzuki dealer inspect your motorcycle to determine the difficulty. Do not operate the motorcycle when the light is lit as it may cause serious damage to the internal parts of the engine or transmission.

FUEL METER (10)

The fuel meter indicates the amount of gasoline remaining in the fuel tank. The "E" mark indicates the tank is empty or nearly so. The "F" mark indicates the fuel tank is full.

SIDE STAND CHECK LIGHT AND BUZZER (11)

With the side stand in down position and with the engine started, the side stand check light should flicker if the transmission is in neutral. And a buzzer sound should be heard at the same time if the transmission is in gear.

LEFT HANDLEBAR

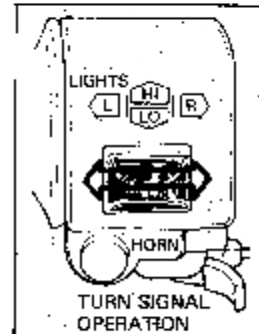
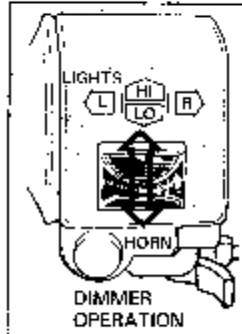
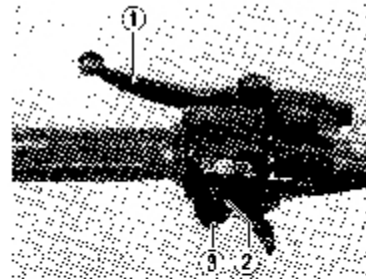

PARKING BRAKE LEVER (1)

To lock the parking brake lever, push the knob in and squeeze the lever, then push the knob again. This locks the rear wheel and turns the parking brake indicator light on. Check that the rear wheel is locked. To release the parking brake, simply squeeze the lever. Check that the rear wheel is free and the indicator light is off.

WARNING:

Never operate the parking brake while moving the motorcycle.

WARNING:

Do not open the throttle or rev the engine while stopped in gear. The motorcycle may move forward.

LIGHTS OPERATING SWITCH (2)

Dimmer operation

When the lights operating switch is pushed up to the "HIGH" position, the high beam will be lit and the switch will return to the center position. At the same time that the high beam is lit, the high beam indicator will also light in the instrument panel. When the switch is pushed down to the "LO" position, the low beam will be lit and the switch will return to the center position.

Turn signal operation

Sliding the lights operating switch to the "L" position will flash the left turn signal. Moving the switch to the "R" position will flash the right turn signal. The indicator light will also flash intermittently.

WARNING

Always use the turn signal when you intend to change lanes or make a turn. ALWAYS be sure to turn the turn signal switch to the "OFF" position after completing the turn or lane change.

HORN BUTTON (3)

Press the button to operate the horn.

RIGHT HANDLEBAR

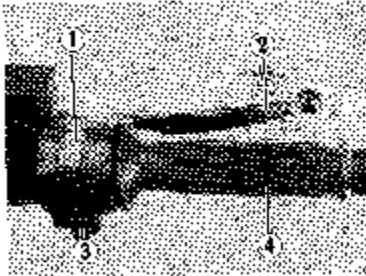

- (1) Engine kill switch (2) Front brake lever
(3) Electric starter button (4) Throttle grip

ENGINE KILL SWITCH

The engine "kill switch" is located on the top of the right handlebar grip switch housing. This is a "rocker" style switch which pivots in the center.

In the "RUN" position the ignition circuit is on and the engine will operate. The switch is intended primarily as an emergency switch. When the switch is in the "OFF" position neither the starter motor nor the ignition circuit will be energized.

FRONT BRAKE LEVER

The front brake is applied by squeezing the brake lever gently towards the throttle grip. This motorcycle is equipped with a disc brake and excessive pressure is not required to slow the machine down properly. The brake light will be lit when the lever is squeezed inward.

ELECTRIC STARTER BUTTON

Push the electric starter button in to engage the starter motor.

NOTE: The starter interlock switch is equipped on this motorcycle. If the transmission is not in neutral, the starter motor will not rotate.

CAUTION:

Do not engage the starter motor for more than five (5) seconds at a time as it may overheat the wiring harness and starter motor. If the engine does not start after several attempts, check the fuel supply and ignition system. (Refer to the troubleshooting section.)

THROTTLE GRIP

Engine speed is controlled by the position of the throttle grip. Twist it toward you to increase engine speed. Turn it away from you to decrease the engine speed.

FUEL TANK CAP



The fuel tank cap is a new low profile style which blends in smoothly with the lines of the fuel tank. To open the fuel tank cap insert the ignition key and turn the key clockwise. With the key still held in a clockwise position, lift up on the key and remove the filler cap. To install the fuel tank cap, face the arrow mark forward, simply line up the fuel tank cap guide pins and push down until the locking pins click into position. The key must be in the cap lock before installing cap. Turn the key counter-clockwise and remove it.

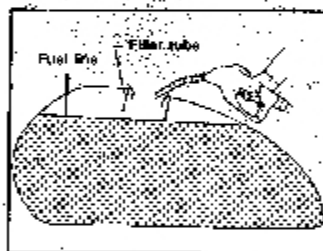

WARNING

Do not overfill the fuel tank. Avoid spilling fuel on the hot engine. Do not fill the fuel tank above the bottom of the filler tube as shown in the illustration or it may overflow when the fuel heats up later and expands.

WARNING

When re-fueling, always shut the engine off and turn the ignition key to the "OFF" position. Never refuel near an open flame.

CARBURETOR CHOKE LEVER



The carburetors of this motorcycle are equipped with a "choke" system to provide easy starting. When starting a cold engine, turn the choke lever all the way left and engage the electric starter. Immediately after the engine starts, return the choke lever halfway. The choke system will operate only when the throttle is in the closed position as opening the throttle will bypass the choke system. When the engine is warm, the choke system does not need to be used for starting. Always be certain to return the choke lever back to its normal position after the engine reaches normal operating temperatures.

FUELCOCK

This motorcycle is equipped with an automatic type, diaphragm style fuelcock. There are three positions: "ON", "RESERVE" and "PRIME".



"ON" The normal position for the fuelcock lever is in the "ON" position. In this position, no fuel will flow from the fuelcock to the carburetors unless the engine is running or being started.



"RESERVE"

If the fuel level in the tank is too low, turn the lever to the "RESERVE" position to use the reserve fuel supply. In this position, no fuel will flow from the fuelcock to the carburetors unless the engine is running or being started.

RESERVE FUEL SUPPLY: 2.0 L
(2.1 US qt)



"PRIME"

If the motorcycle has run out of fuel or has been stored for an extended period, there may not be any gasoline in the carburetors. In this instance the fuelcock lever should be moved to the "PRIME" position. This will allow the fuel to flow directly into the carburetors even though the engine is not operating. Upon starting the engine, be sure to return the lever to the "ON" position or, if necessary, to the "RESERVE" position.

CAUTION:

Leaving the fuelcock in the "PRIME" position may cause the carburetors to overflow and fuel to run into the engine. It is possible that this may cause severe mechanical damage when the engine is started.

NOTE: After switching the fuelcock lever to the "RESERVE" position, it is advisable that the tank be refilled at the closest gas station. After re-fueling, be sure to move the fuelcock to the "ON" position.

GEARSHIFT LEVER

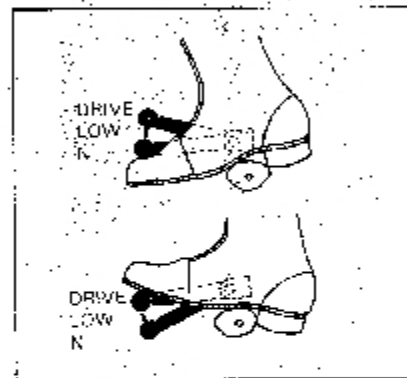

This motorcycle is equipped with a 2 speed constant mesh transmission which operates as shown in the figure. The shift lever is attached to a ratchet type mechanism in the transmission. Each time that a gear is selected, the gear shift lever will return to its normal position ready to select the next gear. Shifting into the "LOW" and "DRIVE" range gears is accomplished by lifting up on the shift lever once for each gear. It is not possible to up shift or down shift more than one gear at a time due to the ratchet mechanism being used.

CAUTION:

Do not shift gears without closing the throttle. The engine and drive train could be damaged by over rev and shock.

REAR BRAKE PEDAL

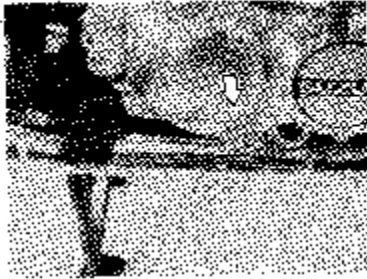

Depressing the rear brake pedal will apply the rear brake. The brake light will be illuminated when the rear brake is operated.

HELMET HOLDER



The helmet holder is located under the left side of the seat. Insert the key, and twist it clockwise to open one of the latches and twist it counterclockwise to open the other side of the latches. Hook your helmet fastener ring to the latch and return back the latch to the closed position to lock the holder.

WARNING:

Do not operate the motorcycle with a helmet fastened to the helmet holder. The helmet may be caught in the wheel causing an accident, or interfere with the safe operation of the motorcycle.

STANDS

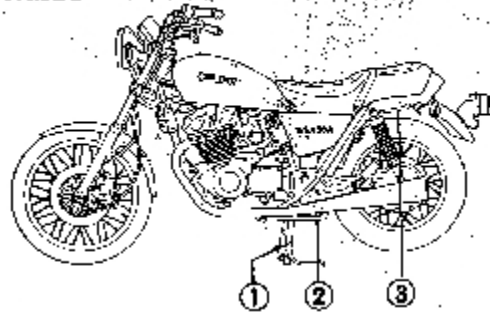

(1) Center stand (2) Side stand (3) Lift bar

The motorcycle is equipped with both a center stand and a side stand. To place the motorcycle on the center stand, place your foot firmly on the stand extension and then rock the motorcycle to the rear and upward with the lift bar with your right hand, while steadying the handlebars with your left hand.

WARNING:

Before starting off, check that the side stand is returned to its normal up position.

FUEL AND OIL RECOMMENDATIONS

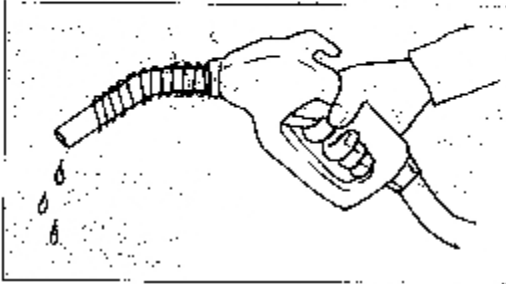

FUEL

Use only unleaded or low-lead type gasoline of at least 85-95 pump octane ($\frac{R+M}{2}$ method) or 89 octane or higher rated by the Research method. If engine pinging is experienced, substitute another brand as there are differences between brands.

NOTE: Unleaded and low-lead gasoline will extend spark plug life.

GEAR OIL

Use an SAE 90 hypoid gear oil which is rated GL-5 under the API classification system. If you operate the motorcycle where ambient temperature is below 0°C (32°F), use an SAE 80 hypoid gear oil.

ENGINE OIL



SUZUKI recommends the use of **SUZUKI PERFORMANCE 4-MOTOR OIL** or an oil which is rated SE or SF under the API (American Petroleum Institute) classification system. The viscosity rating should be SAE 10W-40. If an SAE 10W-40 oil is not available, select an alternate according to the chart below.

CAUTION:

A.T.F. (Automatic Transmission Fluid) is not suitable for this engine. It may cause serious engine damage. Be sure to use recommended engine oil.

This is a very high performance, SAE 10W-40 SF oil with special friction modifier added.

SAE 40	30-40
30	20-30
20W-50	10-20
10W-50	0-20
10W-30	0-30
20W	0-20
10W	0-10
Temperature	°C -20 -10 0 10 20 30 40
	°F 4 14 32 50 68 86 104

BREAK-IN

The foreword explains how important proper break-in is to achieving maximum life and performance from your new Suzuki. The following guidelines explain proper break-in procedures.

MAXIMUM SPEED RECOMMENDATIONS

This table shows the maximum recommended motorcycle speed during the break-in period.

Initial 1 000 miles (1 600 km)	L	12 miles/h (20 km/h)
	D	55 miles/h (90 km/h)

VARY THE ENGINE SPEED

The engine speed should be varied and not held at a constant speed. This allows the parts to be "loaded" with pressure, and then unloaded, allowing the parts to cool. This aids the mating process of the parts. It is essential that some stress be placed on the engine components during break-in to ensure this mating process. Do not, though, apply excessive load on the engine.

AVOID CONSTANT LOW SPEED

Operating the engine at constant low speed (light load) can cause parts to glaze and not seat in. Allow the engine to accelerate freely through the gears, without exceeding the recommended maximum limits. Do not, however, use full throttle for the first 1 000 miles (1 600 km).

ALLOW THE ENGINE OIL TO CIRCULATE BEFORE RIDING

Allow sufficient idling time after warm or cold engine start up before applying load or revving the engine. This allows time for the lubricating oil to reach all critical engine components.

OBSERVE YOUR FIRST, AND MOST CRITICAL, SERVICE

The 600 miles (1 000 km) service is the most important service your motorcycle will receive. During break in all of the engine components will have worn in and all of the other parts will have seated in. All adjustments will be restored, all fasteners will be tightened, and the dirty oil and oil filter will be replaced.

Timely performance of the 600 miles service will ensure optimum service life and performance from the engine.

CAUTION:

The 600 miles service should be performed as outlined in the Maintenance Schedule section of the Owner's Manual. Pay particular attention to the CAUTION and WARNING in that section.

INSPECTION BEFORE RIDING

Before riding the motorcycle, be sure to check the following items. Never underestimate the importance of these checks. Perform all of them before riding the machine.

WHAT TO CHECK	CHECK FOR
Steering	1) Smoothness 2) No restriction of movement 3) No play or looseness
Brakes	1) Correct pedal and lever play 2) No "sponginess" 3) No fluid leakage
Tires	1) Correct pressure 2) Adequate tread depth 3) No cracks or cuts
Fuel	Enough fuel for the planned distance of operation
Lighting	Operation of all lights: HEADLIGHT, TAILLIGHT, BRAKE LIGHT, INSTRUMENT LIGHTS, TURN SIGNALS
Indicator Lights	Oil pressure, High beam, Neutral, Turn signal, Side stand, Gear position, Fuel
Horn and "Kill Switch"	Correct function
Engine Oil	Correct level
Throttle	1) Correct play in the throttle cable 2) Smooth operation and positive return of the throttle grip to the closed position
Gear Oil	Correct level
A - Forks	1) Smooth movement 2) Recommended air pressure

RIDING TIPS

STARTING THE ENGINE

Check that the fuelcock lever is in the "ON" position and that the engine kill switch is in the "RUN" position. Insert the ignition key into the ignition switch and turn it clockwise one notch to the "ON" position. The green light of the gear position indicator lights will light if the transmission is in neutral.

CAUTION:

Always start the engine with the transmission in neutral, the parking brake lever pulled in, and the rider in the normal riding position.

When the engine is cold:

Turn the choke lever all the way to the left. Close the throttle completely. Push the electric starter button and the engine will start. Immediately after the engine starts, return the choke lever halfway. Return the choke lever all the way to its normal disengaged position approximately 40 seconds after the engine starts. In extremely cold weather it may be necessary to use the choke longer than 40 seconds.

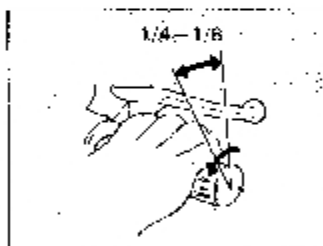

When the engine is warm:

Open the throttle 1/8th to 1/4th turn and push the electric starter button. Operation of the carburetor choke system is usually not necessary when the engine is warm.

WARNING:

Do not run the engine indoors where there is little or no ventilation available. Carbon monoxide fumes are extremely poisonous. Never leave the engine running while unattended, even for a moment.

CAUTION:

Do not let the engine run excessively without riding, or it will overheat and may damage internal engine components or damage the exhaust system chrome plating.

STARTING OFF

Release the parking brake. Check the parking brake indicator light is gone out. Apply front brake and keep the throttle closed when you shift into "LOW" range gear. Release the front brake and twist the throttle grip toward you and the motorcycle will start moving forward.

To shift to the "DRIVE" range gear, close the throttle completely and lift the gearshift lever upward.

USING THE TRANSMISSION

The transmission is provided to keep the engine operating smoothly in its normal operating rpm range. The gear ratios have been carefully chosen to meet the characteristics of the engine. The rider should always select the most suitable gear for the prevailing conditions. The table below shows the gearshifting point for each gear.

Shifting schedule

LOW → DRIVE	12 miles/h (20 km/h)
DRIVE → LOW	3 miles/h (5 km/h)

NOTE: The maximum speed in "L" range as shown in the speedometer (60 km/h (60 mph)) indicates the L-range vehicle speed limit that corresponds to the maximum allowable engine revolution. Do not confuse this with the gearshifting point of speed.

RIDING ON HILLS

- When climbing steep hills, the motorcycle may begin to slow down and show lack of power. At this point you should shift to a lower gear so that the engine will again be operating in its normal power range. Shift rapidly to prevent the motorcycle from losing momentum.
 - When riding down a steep hill, the engine may be used for braking by shifting to low gear range.
- Be careful, however, not to allow the engine to over rev.

WARNING

- (1) If this is the first time that you have ridden a machine of this type, we suggest that you practice on a non-public road to become thoroughly familiar with the controls and operation of the motorcycle.
- (2) Before starting off, always return the side stand to its normal "up" position.
- (3) Slow down to a safe speed before negotiating a corner.
- (4) Don't down shift in the midst of cornering.
- (5) One-hand riding is extremely dangerous. Keep both hands firmly on the handlebars and both feet securely on the foot rests. Under no circumstances should both hands be removed from the handlebars.

STOPPING AND PARKING

- Twist the throttle grip away from yourself to close the throttle completely.
- Apply the front and rear brakes evenly and at the same time.
- Downshift the gear as the motorcycle speed decreases below 3 miles (5 km/h).

NOTE: Inexperienced riders tend to use the rear brake only. This can lead to premature brake wear and excessive stopping distances.

WARNING

Using only the front or rear brake is dangerous and can cause skidding and loss of control. Apply the brakes lightly and with great care on a wet highway pavement or other slippery surfaces and at all corners. Any abrupt braking on slippery or irregular roads can cause loss of rider control.

WARNING

Do not rely on engine brake to slow down the motorcycle, especially at low speed. The SUZUKIMATIC transmission on this motorcycle provides less engine brake than a standard transmission.

- For momentary stops, leave the transmission in gear and apply the brakes while idling.
- Shift to neutral for extended idling.

WARNING

Do not open the throttle or rev the engine while stopped in gear. The motorcycle may move forward.

- Apply the brakes lightly and with great care on a wet highway pavement or other slippery surfaces and at all corners. Any abrupt braking on slippery or irregular roads can be particularly dangerous.
- If the motorcycle is to be parked on the side stand and on a slight slope, engage the parking brake to prevent it from rolling off the side stand.
- Turn the ignition switch to the "OFF" position to stop the engine.
- Lock the steering for security.
- Remove the ignition key from the switch.

HIGH SPEED RIDING

The rear suspension setting should be adjusted to meet the suspected road conditions and motorcycle speeds. Tire pressures should also be increased for high speed riding as described in tire pressure section.

WARNING

High speed cruising requires special care. Be sure that you review the provide instruction chart and be sure that your machine is in top condition. Do not exceed the posted speed limits.

INSPECTION AND MAINTENANCE

NOTICE (to owners in USA)

MAINTENANCE, REPLACEMENT OR REPAIR OF THE EMISSION CONTROL DEVICES AND SYSTEMS MAY BE PERFORMED BY ANY MOTORCYCLE REPAIR ESTABLISHMENT OR INDIVIDUAL USING ANY MOTORCYCLE PART WHICH HAS BEEN CERTIFIED UNDER THE PROVISIONS IN THE CLEAN AIR ACT Sec. 207 (a)(2).

MAINTENANCE SCHEDULE

The chart indicates the intervals between periodic services in miles (kilometers) and months. At the end of each interval, be sure to inspect, check, lubricate and service as instructed. If your motorcycle is used under high stress conditions such as continuous full throttle operation, or is operated in a dusty climate, certain services should be performed more often to insure reliability of the machine as explained in the maintenance section. Your Suzuki dealer can provide you with further guidelines. Steering components, suspension and wheel components are key items and require very special and careful servicing. For maximum safety we suggest that you have these items inspected and serviced by your authorized Suzuki dealer or a qualified service mechanic.

CAUTION:

Periodical inspections may reveal one or more parts that may need replacement. Whenever replacing parts on your motorcycle, it is recommended that you use Genuine Suzuki replacement parts or their equivalent. Whether you are an expert or do-it-yourself mechanic, Suzuki recommends that those items on the Inspection Chart marked with an asterisk (*), be performed by your authorized Suzuki dealer or qualified service mechanic. You may perform the unmarked items easily by referring to the instructions in this section.

WARNING:

Proper break-in maintenance (600 miles or 1 000 km) is a **MANDATORY** item for making certain that your machine is reliable and gives full performance at all times. Be sure that this periodic maintenance is performed thoroughly and in accordance with the instructions in this manual.

INTERVAL: THIS INTERVAL SHOULD BE JUDGED BY ODOMETER READING OR MONTHS, WHICHEVER COMES FIRST	miles	600	4 000	7 500	11 000	15 000
	km	1 000	6 000	12 000	18 000	24 000
	months	2	12	24	36	48
Battery (Specific gravity of electrolyte)	-	I	I	I	I	I
*Cylinder head nut & exhaust pipe bolt	T	T	T	T	T	T
Air cleaner element	-	C	C	C	C	C
*Tappet clearance	I	I	I	I	I	I
Spark plug	-	C	R	C	R	R
*Fuel line	I	I	I	I	I	I
Engine oil and oil filter	R	R	R	R	R	R
Carburetor idle rpm	I	I	I	I	I	I
Clutch	I	I	I	I	I	I
Drive shaft gear oil	Change oil at initial 600 miles (1 000 km) and thereafter every 7 500 miles (12 000 km).					
*Brake hoses	I	I	I	I	I	I
*Brake fluid	Replace every four years					
*Brake	Change every two years					
Tires	I	I	I	I	I	I
*Steering stem	I	I	I	I	I	I
*Chassis bolts and nut	T	T	T	T	T	T
Front fork	-	-	I	-	-	-
Check air pressure every 6 months						

NOTE: T = Tighten, C = Clean, I = Inspect, R = Replace

TOOLS

To assist you in the performance of periodic maintenance, a tool kit is supplied and is provided inside of the right frame cover. The tool kit consists of the following items.

Ref. No.	Item
1.	Tool Bag
2.	8mm Open End Wrench
3.	10 x 12mm Open End Wrench
4.	14 x 17 mm Open End Wrench
5.	Spark Plug Socket Wrench
6.	19mm Ring Wrench
7.	24mm Ring Wrench
8.	Box Wrench Handle
9.	Ring Wrench Handle
10.	Combination Screwdriver
11.	Cross Head Screwdriver
12.	Screwdriver Handle
13.	Pliers
14.	Swinging arm Wire
15.	Front Fork Air Pressure Gauge

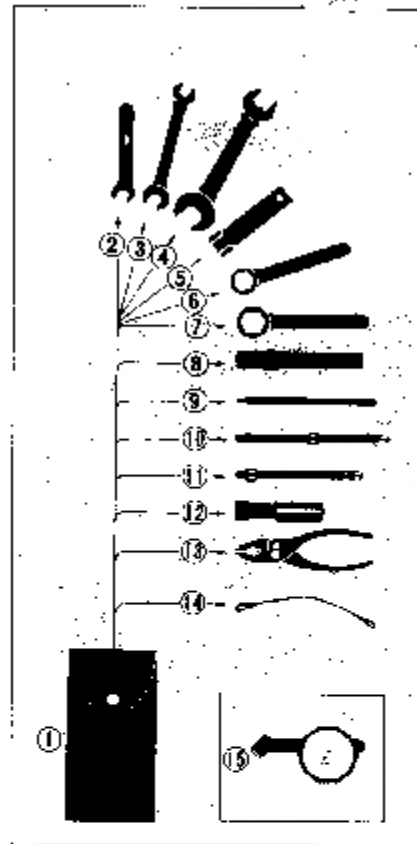

OILING POINTS

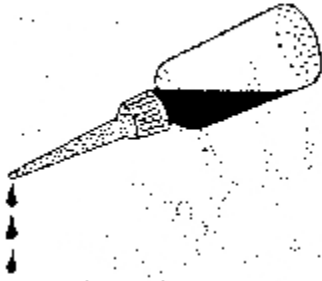

Proper lubrication is important for smooth operation and long life of each working part of your motorcycle and also for safe riding. It is a good practice to oil the machine after a long rough ride and after getting it wet in the rain or after washing it.

BATTERY



The battery solution level may be inspected by removing the right frame cover. The solution level must be kept between the upper and lower level lines at all times. If the solution level is below the lower limit line, add **ONLY** distilled water up to the upper limit line. **NEVER** use tap water.

WARNING:

Once the battery has been initially serviced, **NEVER** add diluted sulphuric acid.

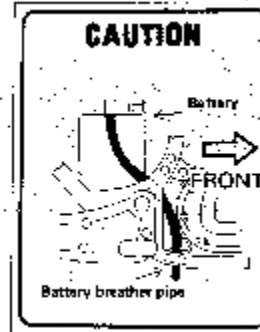

CAUTION:

Do not bend, obstruct or change the routing of the air vent tube from the battery. Make certain that the vent tube is attached to the battery vent fitting and that the opposite end is always open. Route the battery vent tube and locate the battery exactly as shown.

CAUTION:

When attaching the wiring harness battery leads to the battery terminals, observe the correct polarity. The red lead must go to the (+) (positive) terminal and the black (or black with white tracer) lead must go to the (-) (negative) terminal. Reversing these connections will damage the charging system and the battery.

NOTE: Every 4 000 miles (6 000 km) have your dealer check the specific gravity of the battery's cells with a battery hydrometer. This will determine the exact condition of each of the six (6) cells.

AIR CLEANER



(1) Screw
(2) Wing bolt
(3) Air cleaner case cover

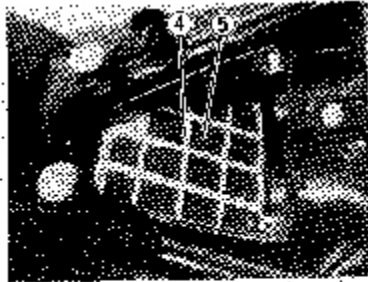

(4) Element frame
(5) Polyurethane foam element

If the air cleaner is clogged with dust, intake resistance will increase with a resultant decrease in output and an increase in fuel consumption. Check and clean the cleaner every 4 000 miles (6 000 km) according to the following procedures.

- (1) Remove the seat.
- (2) Loosen the two screws and the wing bolt, then remove the air cleaner case cover.
- (3) Take out the air cleaner element frame.
- (4) Remove the polyurethane foam element.

WASHING THE ELEMENT

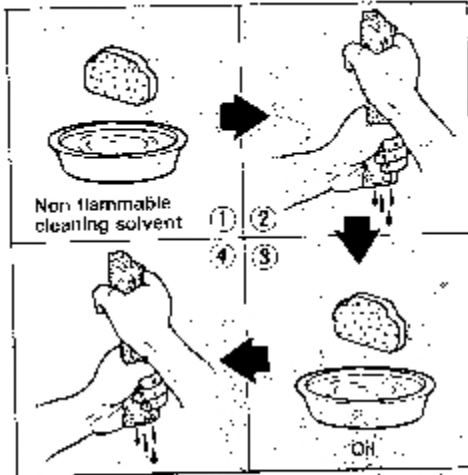

Wash the element as follows:

- 1) Fill a washing pan of a proper size with non-flammable cleaning solvent. Immerse the element in the solvent and wash it clean.
- 2) Squeeze the solvent of the washed element by pressing it between the palms of both hands. Do not twist or wring the element, or it will develop fissures.
- 3) Immerse the element in a pool of motor oil, and squeeze the oil off the element to make it slightly wet with the oil.

CAUTION:

Before and during the cleaning operation, carefully examine the element for any tears in the material. A torn element must be replaced with a new one.

- 4) Reinstall the cleaned element in reverse order of removal. Be absolutely sure that the element is securely in position and is sealing properly.

CAUTION:

If driving under dusty conditions, the air cleaner element must be cleaned more frequently. **NEVER OPERATE THE ENGINE WITHOUT THE ELEMENT IN POSITION.** Operating the engine without the air cleaner element will increase engine wear. Always be sure that the air cleaner element is in excellent operational condition at all times. The life of the engine depends largely on this single component.

SPARK PLUGS

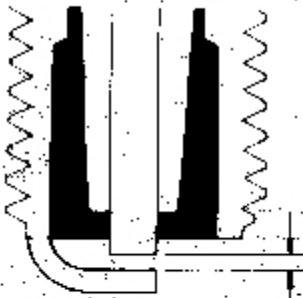

0.6–0.8 mm
(0.024–0.031 in)

SPARK PLUGS

At every 4 000 miles (6 000 km), remove the carbon deposits from the spark plug with a piece of hard wire or pin. Readjust the spark gap to 0.6–0.8 mm (0.024–0.031 in) by using a spark plug gap thickness gauge. The spark plug should be replaced every 7 500 miles (12 000 km).

Whenever removing the carbon deposits, be sure to observe the operational color of each spark plug's porcelain tip. This color tells you whether or not the standard spark plug is suitable for your type of usage. If the standard plug is wet appearing or very dark in color, the hotter spark plug may be more suitable. A normal operating spark plug should be very light brown or tan color. If the spark plug is very white or glazed appearing, then it has been operating much too hot. This spark plug should be replaced with the colder plug.

CAUTION:

The standard spark plug for this motorcycle has been carefully selected to meet the vast majority of all operational ranges. If the spark plug color indicates that other than a standard spark plug be used, it is best to consult your Suzuki

dealer before selecting an alternate plug or heat range. The selection of an improper spark plug can lead to severe engine damage.

CAUTION:

Do not overtorque or cross thread the spark plugs or the aluminum threads of the cylinder head will be damaged. Do not allow contaminants to enter the engine through the spark plug holes when the plugs are removed.

Plug replacement guide

NGK	NIPPON DENSO	REMARKS
B7ES	W22ES-U	If the standard plug is apt to get wet, replace with this plug.
B8ES	W24ES-U	Standard
B9ES	W27ES-U	If the standard plug is apt to overheat, replace with this plug.

ENGINE OIL

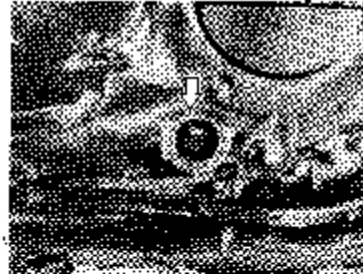

Engine oil inspection window

Superior engine life depends much on the selection of quality oil and the periodic changing of the oil. Daily oil level checks and periodic changes are two of the most important maintenances to be performed.

CAUTION:

Never operate the motorcycle if the engine oil level is below the "L" (low) line in the inspection window. Never fill the engine oil level above the "F" (full) line.

ENGINE OIL AND FILTER CHANGE

Change the engine oil and oil filter at the initial 800 miles (1 000 km) and also at the every 4 000 miles (6 000 km). The oil should always be changed when the engine is hot so that the oil will drain thoroughly from the engine. The procedure is as follows:

NOTE: About 2 800 ml (3.0 US qt.) of oil will be required when changing oil without replacing the oil filter.

- (1) Place the motorcycle on the center stand.



Oil filler cap

- (2) Remove the oil filler cap.



Drain plug

Drain plug
(Under the secondary
gear case)

- (3) Drain the engine oil by removing the drain plug from the bottom of the engine and secondary gear case.



(1) Nut (2) Filter cap

- (4) Remove the three nuts holding the filter cap in place.



Oil filter

- (5) Remove the filter cap, pull out the element and replace with a new oil filter element.

CAUTION:
Insert the filter with the open end into the engine.

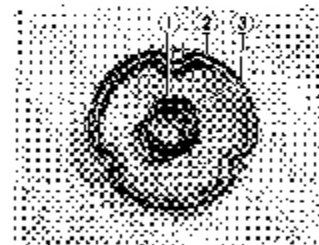

(1) Spring
(2) "O" ring
(3) Filter cap

- (6) Before replacing the oil filter cover, check to be sure that the filter spring and the cap "O" ring are installed correctly. Insert a new "O" ring each time the filter element is replaced.
- (7) Replace the oil filter cover and tighten the nuts securely but do not over-tighten them.
- (8) Replace the drain plugs and tighten them securely. Add fresh oil through the filler hole approximately 3-200 ml (3.4 US qt) will be required.
- (9) Start the engine and allow it to idle for several seconds. Check to see that no oil is leaking from the oil filter cover.
- (10) Turn the engine off and wait approximately one minute, then recheck the oil level in the engine oil inspection window. The oil level should be at the "F" line. If the oil level is lower than the "F" line, pour fresh oil until it reaches the "F" line.

CAUTION:

Be sure to always use the specified engine oil described on FUEL AND OIL RECOMMENDATION section.

GEAR OIL CHANGE

Change the gear oil at initial 1 000 km (600 miles), and thereafter every 12 000 km (7 500 miles). Use SAE 90 hypoid gear oil which is rated GL-5 under API classification system. If you operate the motorcycle where ambient temperature is below 0°C (32°F), use SAE 80 hypoid gear oil. The procedure is as follows:

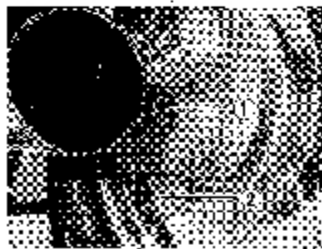

(1) Oil filter cap (2) Drain plug

FINAL GEAR OIL CHANGE

1. Place the machine on the center stand.
2. Remove the oil filler cap.
3. Drain the oil by removing the drain plug from the bottom of the final gear case.
4. Reinstall the drain plug and tighten it securely after all the oil has been drained out. Add fresh oil through the filler hole until the oil drains out from the oil filler hole. Approximately 200-220 ml (0.42-0.46 US pt) of oil will be required.
5. Reinstall the oil filler cap.

CARBURETOR

Undisturbed carburetion is the basis of the performance you ought to expect of your engine. The carburetor is factory set for the best carburetion. Do not attempt to alter its setting. There are two items of adjustment, however, under your care: carburetor idle rpm and throttle cable play. Adjust the carburetor idle rpm and throttle cable play at initial 600 miles (1 000 km) and every 4 000 miles (6 000 km).

CARBURETOR IDLE RPM ADJUSTMENT



Throttle stop screw

- (1) Start up the engine and warm it up by running it at 2 000 rpm for 10 minutes in summer (where ambient temperature is 30°C (86°F) or thereabout) or for 20 minutes in winter (where ambient temperature is down to -5°C (23°F) or thereabout).
- (2) After engine warms up, turn the throttle stop screw located on the carburetor in or out so that engine may run at 1 200-1 300 rpm.

NOTE: If you have a tachometer you can do this adjustment by referring to the procedures described above.

CAUTION:

The carburetor idle rpm should be adjusted with the engine fully warm.

THROTTLE CABLE ADJUSTMENT

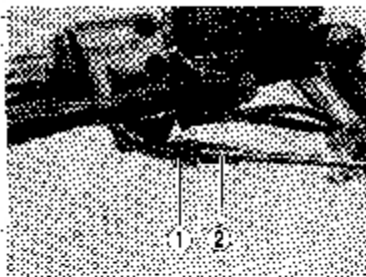

(1) Lock nut (2) Throttle cable adjuster

- 1) Loosen lock nut.
- 2) Adjust the cable slack by turning adjuster in or out to obtain the correct slack 0.5-1.0 mm (0.02-0.04 in).
- 3) After adjusting the slack, tighten the lock nut.

WARNING:

After completing throttle cable adjustment, check that handlebar movement does not raise the engine idle speed and that the throttle grip returns smoothly and automatically.

CAMSHAFT DRIVE CHAIN TENSIONER



The camshaft drive chain is kept in proper adjustment by an AUTOMATIC camshaft drive chain tensioner. This automatic tensioner never needs servicing by the customer and the camshaft drive chain itself need not be checked for stretch or wear.

CAUTION:

Never attempt to turn the tensioner wheel in either direction. Turning the wheel even slightly can jam the mechanism which will prevent it from adjusting the chain properly. An improperly adjusted chain can cause severe engine damage.

BRAKES

Properly operating brake systems are vital to safe riding. Be sure to perform the brake inspection requirements as scheduled. The brakes should be inspected at the initial 600 miles (1 000 km) inspection and every 4 000 miles (6 000 km) thereafter, by your authorized Suzuki dealer.

BRAKE FLUID

WARNING:

Brake fluid may be harmful if swallowed or if it comes in contact with skin or eyes. Contact your physician immediately. If swallowed induce vomiting. If brake fluid gets into the eyes or in contact with the skin, it should be flushed thoroughly with plenty of water.

WARNING:

This motorcycle uses a glycol-based brake fluid. Do not use or mix different types of brake fluid such as silicone-based or petroleum-based fluid, otherwise serious damage will result to the brake system. Never use any brake fluid that has been stored in a used or unsealed container. Never reuse brake fluid left over from the last servicing and stored for long periods as it absorbs moisture from the air. Use only DOT 3 or DOT 4 brake fluid. Do not spill any brake fluid on painted or plastic surfaces as it will damage the surface severely.

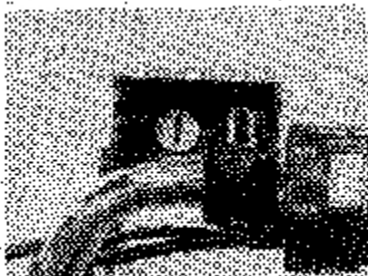

Front reservoir

Be sure to check the brake fluid level in the front reservoir. If the level was found to be lower than the lower mark, replenish with the proper brake fluid that meets Suzuki's requirements. As the brake pads wear, the fluid level will drop to compensate for the new position of the brake pads. Replenishing the brake fluid reservoir is considered normal periodic maintenance.



Front brake pad

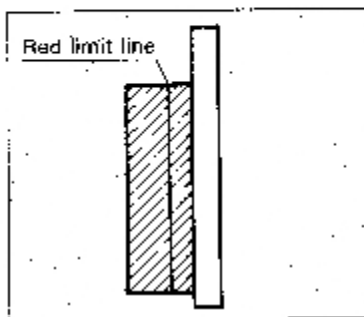

Inspect the front brake pads by noting whether or not the friction pads are worn down to the red limit line. If a pad is worn to the red limit line it must be replaced with a new one.

WARNING:

If the brake system or pads need to be repaired or serviced we strongly advise you to have your authorized Suzuki dealer perform service. He has the proper tools and proper training to perform the job in a safe and economical manner.

CAUTION:

Disc brake systems operate under extremely high pressures. For safety, the brake hose and brake fluid should be changed at intervals of no longer than those scheduled in **MAINTENANCE SCHEDULE** section of this manual.

Inspect your brake system for the following items daily.

- (1) Inspect the front brake system for signs of fluid leakage.
- (2) Inspect the brake hose for leakage or a cracked appearance.
- (3) The brake lever should have the proper stroke and be firm at all times.
- (4) Check the wear of the disc brake pads.

WARNING:

After front disc brake pad replacement, do not ride the motorcycle until the brake lever has been "pumped" several times to extend the pads and restore the proper lever stroke and firm feel.



Pedal stopper



Adjusting nut

REAR BRAKE ADJUSTMENT

When adjusting the travel of brake pedal, first set the pedal at its proper position for comfortable riding by turning the brake pedal stopper, and then adjust the free travel to 20-30 mm (0.8-1.2 in) by screwing in or out the brake adjusting nut.

BRAKE LINING WEAR LIMIT

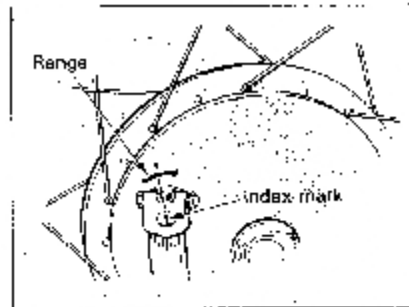

Fig. A The extension line of the index mark is within the range.



Fig. B The extension line of the index mark is out of the range.

Brake lining wear limit:

The motorcycle is equipped with the brake lining wear limit indicator on rear brake. To check wear of the brake lining, perform the following:

- 1) Check if the brake system is properly adjusted.
- 2) While fully applying the brake, check to see that the extension line of the index mark is within the range on the brake panel as shown in the figure A.
- 3) If the extension line is beyond the range as shown in the figure B, have the brake shoe assembly replaced by your Suzuki dealer to insure safe operation.

PARKING BRAKE ADJUSTMENT

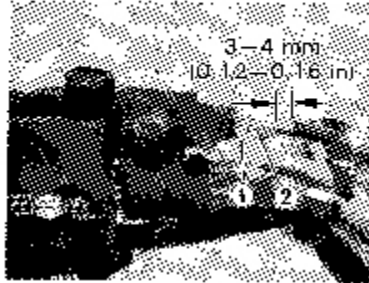

(1) Lock nut (2) Adjuster

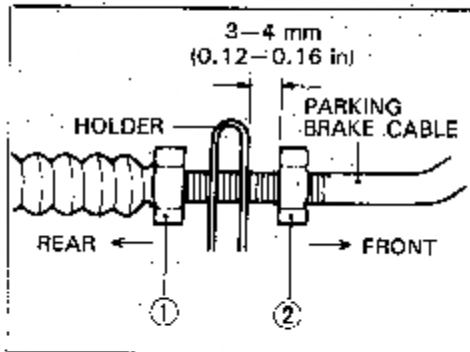
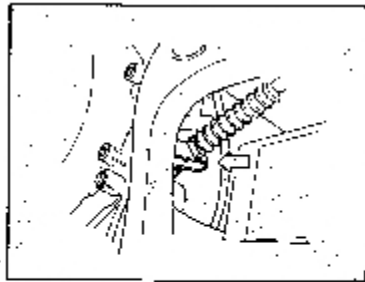

This adjustment must be done with the rear brake pedal play properly adjusted. The procedure is as follows:

- (1) Set the parking brake lever to the fully returned position.
- (2) Loosen the lock nut (1) and (2).
- (3) Pull the parking brake cable forward all the way to take up the cable play.
- (4) Holding the cable at that position, provide 3-4 mm (0.12-0.16 in) of clearance between the holder and the nut (2) by turning the nut (2).
- (5) Turn in the nut (1) all the way and tighten it.

(6) Make sure that the 3-4 mm (0.12-0.16 in) of play is provided at the parking brake lever side adjuster. Fine adjustment can be made, if necessary, by this adjuster.

(7) After the adjustment, check that the parking brake functions properly and that the rear wheel turns freely when the brake is released. Also check that the brake system does not interfere with the steering.

FRONT BRAKE LIGHT SWITCH

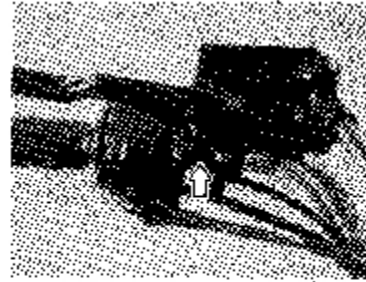

The front brake light switch is located beneath the front brake lever. Loosen the switch fitting screws and adjust the actuating point by moving the switch body to the right or to the left so that the brake light will come on just before a pressure rise is felt at the lever.

REAR BRAKE LIGHT SWITCH



The rear brake light switch is located under the right frame cover. To adjust the brake light switch; raise or lower the switch so that the brake light will come on just before a pressure rise is felt when the brake pedal is depressed.

ADJUSTING THE SIDE STAND CHECK LIGHT SWITCH

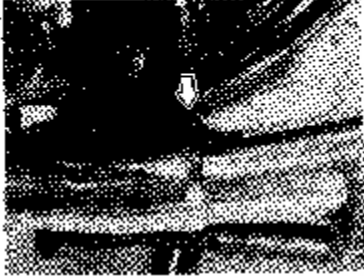

To adjust the side stand check light switch: move the switch right or left so that the check light in the instrument panel will turn off when the side stand is returned to its normal up position.

WARNING

Take care not to burn yourself if the mufflers are hot.

TIRES

Check the tire inflation pressure and tire tread condition at the initial 600 miles (1 000 km) and each 4 000 miles (6 000 km) inspection. For maximum safety and good tire life, the tire pressures should be inspected more often.

TIRE PRESSURE

Insufficient air pressure in the tires not only hastens tire wear but also seriously affects the stability of the motorcycle. Under inflated tires make smooth cornering difficult and overinflated tires decrease the amount of tire in contact with the ground which can lead to skids and loss of control. Be sure that the tire pressure is within the specified limits at all times. Tire pressure should only be adjusted when the tires are cold.

	NORMAL RIDING	
	SOLO RIDING	DUAL RIDING
FRONT	1.75 kg/cm ² 175 kPa 24 P.S.I.	1.75 kg/cm ² 175 kPa 24 P.S.I.
REAR	2.00 kg/cm ² 200 kPa 28 P.S.I.	2.25 kg/cm ² 225 kPa 32 P.S.I.
	CONTINUOUS HIGH SPEED RIDING	
	SOLO RIDING	DUAL RIDING
FRONT	2.00 kg/cm ² 200 kPa 28 P.S.I.	2.00 kg/cm ² 200 kPa 28 P.S.I.
REAR	2.25 kg/cm ² 225 kPa 32 P.S.I.	2.50 kg/cm ² 250 kPa 36 P.S.I.

TIRE TREAD CONDITION

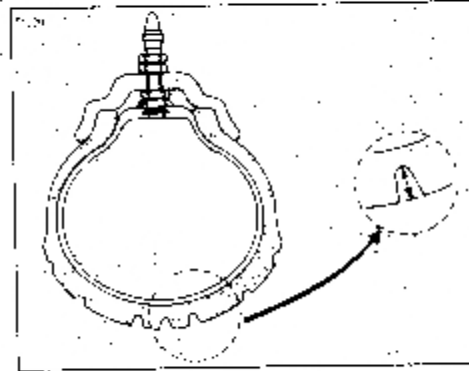

Operating the motorcycle with excessively worn tires will decrease riding stability and can lead to loss of control. It is recommended that the front tire be replaced when the remaining depth of tire tread becomes 1.8 mm (0.06 in) or less. The rear tire should be replaced when the tread becomes 2.0 mm (0.08 in) or less.

WARNING

The standard tire on your motorcycle is 3.60S18 4PR for front, 4.60S 16 4PR for rear. The use of a tire other than standard may cause trouble. It is highly recommended to use the standard tire supplied by SUZUKI.

WARNING:

Tire inflation pressures and the general tire condition are extremely important to the proper performance and safety of the vehicle. Check your tires frequently for both wear and inflation pressures.

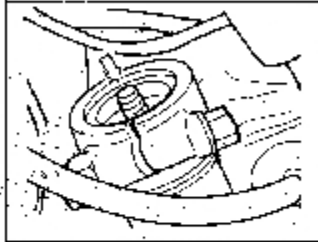
FRONT SUSPENSION

This motorcycle front suspension is pneumatic/coil spring or more commonly referred to as "air" forks. Each fork tube contains compressed air and a light coil spring as well as fork oil.

This motorcycle is serviced at the factory with 0.5 kg/cm² (7.1 psi) of air pressure in the front forks.

CHECKING FORK AIR PRESSURE

The motorcycle should be placed on its center stand and all weight removed from the front end by jacking up the front of the chassis or engine. Remove the air valve protection cap, use the air pressure gauge to check the front fork air pressure. To raise the pressure, use a hand pump to add air to each fork leg. To lower the pressure, bleed the air out from the valve.

CAUTION:

Do not attempt to alter the front fork air pressure setting by using a high pressure tire filler such as is available in gas stations. A hand type pump must be used so that no damage will occur to the fork assembly. Never use any air containing inflammable gases. Instead of ordinary air, nitrogen gas may be substituted if available. When pumping air in, never increase the pressure above 2.5 kg/cm². This is the maximum permissible pressure to avoid fork oil seal and valve damage.

CAUTION:

Never change the air pressure setting. Be sure to keep the front fork air pressure always at 0.5 kg/cm².

NOTE: Fork air pressure, as with tire pressure, should be checked periodically and especially after periods of non-use. When checking the pressure, be sure to apply the pressure gauge squarely to the air valve. After taking a reading, remove the gauge quickly. This must be done as some pressure is lost when removing the gauge. The loss ranges from 0.05 to 0.10 kg/cm². Take this loss of air pressure into consideration when adjusting for your final air pressure.

CAUTION:

Fork oil viscosity and level is critical to proper air fork operation. Drawing or adding fork oil is best left to your Suzuki dealer as special tools and knowledge are necessary to perform this task.

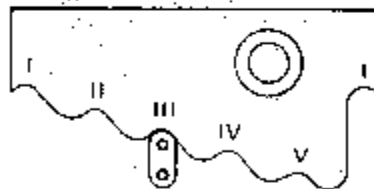
REAR SHOCK ABSORBER

The rear shock absorber spring pre-load is adjustable to compensate for rider, load, riding style and road conditions. The adjustment can be performed in five positions. To change the spring pre-load setting, place the motorcycle on the side or center stand. Using a screw driver or rod, twist the spring tension ring to the desired position. Position (I) provides the softest spring tension and position (V) provides the stiffest.

This motorcycle is delivered from the factory with its adjuster set on the (III) position.

WARNING:

Be sure to adjust the springs of the two absorbers equally. Making one spring stiffer than the other disturbs the running stability of the machine.

FRONT WHEEL REMOVAL

- (1) Place the motorcycle on the center stand.



- (2) Remove the cotter pin that locks the axle nut (1) into position, then loosen the axle.



- (3) Loosen the two axle holder nuts (2).

- (4) Lift the front end of the motorcycle up and place a jack or a block under the engine or chassis tubes.
(5) Draw out the axle.
(6) Slide the front wheel forward. To reinstall the wheel assembly reverse the sequence as described.

WARNING:

If the front wheel has to be removed, it is very important to have the loosened nuts and bolts torqued to the proper specifications. We suggest that you have this performed by an authorized Suzuki Dealer.

CAUTION:

Before tightening the axle holder in place, locate the speedometer drive gearbox so that the cable is routed smoothly without an excessive bend. This will align the speedometer cable properly when installed. To secure the axle properly, the axle holder should be tightened down so that the gap on each side of the cap is equal.

CAUTION:

Never squeeze the front brake lever with the front wheel removed. It is very difficult to force the pads back into the caliper assembly and brake fluid leakage may result.

REAR WHEEL REMOVAL

- (1) Place the motorcycle on the center stand.

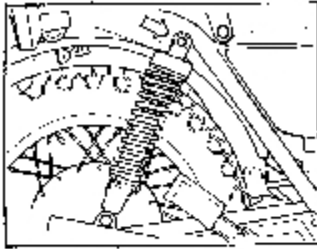

- (2) Remove the right shock absorber upper mounting nut and loosen the lower mounting bolt. Remove the upper mounting from the frame with the lower mounting attached on the swing arm.
- (3) Remove the left shock absorber upper and lower mounting nuts and take off shock absorber.

CAUTION:

Take care not to burn yourself if the mufflers are hot.



- (1) Torque link bolt (2) Brake adjusting nut
- (4) Remove the brake adjusting nut.
 - (5) Remove the cotter pin that locks torque link bolt, then loosen the nut.

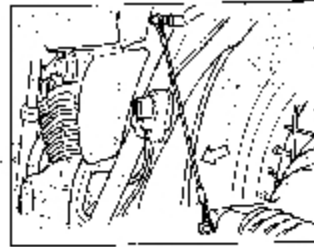

- (6) Lift up the rear wheel and hook a piece of wire to the left side rear shock absorber mounting lugs to hold the swing arm lifted.



- (7) Remove the cotter pin and loosen the axle nut.



- (8) Loosen the axle shaft holder bolt and draw out the axle shaft.



(9) Remove the wheel from the splined drive gear and set the wheel assembly on the ground.



(10) Remove the rear wheel assembly.

WARNING:

If you have found it necessary to remove the rear wheel, it is very important that the nuts and bolts be torqued to the proper specification. We strongly recommend that you have these bolts checked and retorqued by your authorized Suzuki Dealer.

CAUTION:

Check all bolts, nuts and cotter pins after reinstalling the rear wheel.

LIGHT BULB REPLACEMENT

The wattage rating of each bulb is shown on the chart below. When replacing a burned out bulb, always use the exact same wattage rating. Using other than the specified rating can result in overloading the electrical system or premature failure of a bulb.

Headlight	12V 50/35W
Tail/Brake light	12V 8/23W (3/32 cp)
Turn signal light	12V 23W (32 cp)

HEADLIGHT

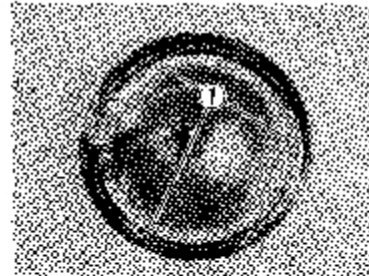
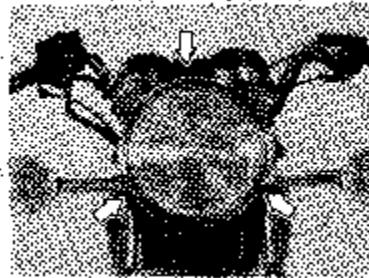

To remove the headlight perform the following steps:

- (1) Remove the three screws from the headlight retainer ring. Remove the headlight.
- (2) Remove the headlight from the wiring harness socket.
- (3) Pulling up the headlight clamp (1) and the bulb unit can now be removed from the retainer ring.

To reinstall the headlight assembly, simply reverse the above sequence listed.

HEADLIGHT BEAM ADJUSTMENT



The headlight beam can be adjusted both horizontally and vertically if necessary.

To adjust the beam horizontally:

Turn the cross head screw ① located on the left side of the headlight unit clockwise or counter-clockwise.

To adjust the beam vertically:

Loosen the headlight housing fitting bolt ② and move the headlight housing up or down as required.

TAILBRAKE LIGHT



To replace the tail/brake light bulb, follow these directions:

- (1) Remove the two screws and take off the lens.
- (2) Push the bulb in, twisting it to the left until the engagement pins are disconnected and remove the bulb. To fit the replacement bulb into position, push the bulb in firmly and twist it to the right while pushing in.

CAUTION:

When replacing the lens, do not overtighten the two securing screws.

TURN SIGNAL LIGHT

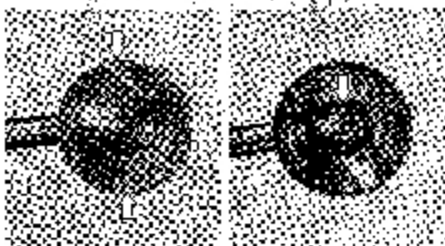

- (1) Remove two screws and take off the lens.
- (2) Push in on the bulb, twisting it to the left, and pull it out.
- (3) To fit the replacement bulb, push it in and twist it to the right while pushing.

CAUTION:

After setting the lens, be careful not to overtighten the two securing screws lest the lens should break.

FUSE



The fuse box is located inside the left hand frame cover. If the engine suddenly stops, then the fuse must be checked. In case the fuse blows there is one spare fuse, a 15A fuse.

CAUTION:

Always be sure to replace the blown fuse with the correct amperage fuse. Never use a substitute, for example aluminum foil or wire, to replace a blown fuse. If the spare fuse installed blows in a short period of time it could mean that you have a major electrical problem. You should consult your Suzuki dealer immediately.

TROUBLESHOOTING

If the engine refuses to start, perform the following inspections to determine the cause.

- (1) Is there enough fuel in the fuel tank?
- (2) Is the fuel reaching the carburetors from the fuelcock?
- (3) Disconnect the fuel line from the carburetor, turn the fuelcock to the "PRIME" position and see if gasoline flows from the hose.
- (4) Then turn the fuelcock to the "ON" position and crank the engine for a brief moment and see if fuel still flows.
- (5) If it has been determined that fuel is reaching the carburetor, the ignition system should be checked next.

WARNING:

Do not allow the fuel to spill. Do not allow any fuel to come in contact with the hot engine or exhaust system. Extinguish any smoking materials before performing this check, and stay away from any other fire or heat source.

- (1) Remove a spark plug and re-attach it to the spark plug lead.
- (2) While holding the spark plug firmly against the engine, push the starter button with the ignition switch in the "ON" position and the engine "kill" switch in the "RUN" position. If the ignition system is operating properly, a blue spark should jump across the spark plug gap. If there is no spark, consult your Suzuki Dealer for repairs.

WARNING:

Do not hold the spark plug close to the open spark plug hole in the cylinder head as gasoline vapor inside the cylinder could be ignited, creating a fire hazard. To reduce the chance of electrical shock, hold the metal shell of the spark plug against an unpainted metal portion of the engine. Due to the possibility of electrical shock, anyone with a heart condition or pacemaker should avoid this check.



ENGINE STALLING

- (1) Check the fuel supply in the fuel tank.
- (2) Check the ignition system for intermittent spark.
- (3) Check the engine idle speed.

CAUTION:

It is best to consult your Suzuki dealer before attempting to troubleshoot any problem. If the machine is still within the warranty, then the Suzuki dealer should definitely be consulted before any repairs are attempted on the machine by yourself. Tampering with the machine while in warranty may affect warranty consideration.

STORAGE PROCEDURE

PROCEDURE FOR STORAGE

Materials Needed:

1. Motor Oil.
 2. Commercial Gasoline Stabilizer.
 3. Commercial Rust Preventative Fogging Oil. (outboard motor type)
 4. Commercial Aerosol Rust Preventative. (moisture displacing lubricant)
 5. Commercial Vinyl and Rubber Preservative.
 6. Hydrometer for Checking Battery Condition.
 7. 1 Amp Battery Charger.
1. Place the motorcycle on its center stand.
 2. Thoroughly clean the entire motorcycle. Run the bike until all traces of moisture are gone.

3. Pour the gasoline stabilizer into the fuel tank using the amount of stabilizer recommended by its manufacturer. Unstabilized fuel will form "gum" or "varnish" deposits that will plug the fuelcock and carburetor passageways.

NOTE: Make sure that the fuelcock lever is in the "ON" or "RESERVE" position. If the lever is left in the prime position, fuel may leak into the engine.

NOTE: Steps 4a and 4b are for protecting the top end engine components from rust and corrosion. Step 4b is to be used only if fogging oil is not available. Do either 4a or 4b, but DO NOT do both.

- 4a. Remove the air cleaner element. While the engine is running at idle, spray the rust preventative fogging oil into the air cleaner box. Try to give each cylinder equal amounts of fogging oil. Do this until the engine stalls or emits smoke.
- 4b. Run the engine for a few minutes to get the stabilized fuel into the carburetors. Then, remove the spark plugs and pour 1 to 2 tablespoons of motor oil into each spark plug hole. Reinstall the spark plugs. DO NOT reinstall the spark plug caps at this time. Turn the engine over a few times with the electric starter. Now reinstall the spark plug caps.
5. Drain the old engine oil and remove the oil filter, but DO NOT replace it at this time. With fresh oil, refill the crankcase all the way up to the filler cap hole. This step is necessary because the old oil contains acid, moisture and other contaminants that will damage the engine while it is stored.
6. Refill the fuel tank as completely as possible to eliminate any air space and to reduce the chances of the fuel becoming contaminated.

7. Remove the battery. Make sure to remove the negative terminal before the positive terminal. This will remove the battery from the circuit and will eliminate the chance of grounding the positive terminal with the screwdriver or wrench. Clean the outside of the battery with a mild baking soda and water solution and dry it carefully. Be sure not to get any solution inside the cells. Remove any corrosion from the terminals and from the wiring harness connections. Store the battery in a room that stays above freezing, off the floor, and preferably on a wooden shelf.
8. Spray all of the vinyl and rubber parts with the rubber preservative.
9. Spray the unpainted surfaces of the motorcycle with the rust preservative.
10. Deflate the tires to approximately 20 PSI and block up the front of the motorcycle so both front and rear tires are off of the ground. This will keep the tires from developing permanent "flat" spots.

During the storage period, be sure to do the following things:

Once A Month

Recharge the battery with the one amp battery charger until it is fully charged. If the battery is not kept fully charged, it may become permanently damaged and will have to be replaced.

PROCEDURE FOR RETURNING TO SERVICE

1. Clean the entire motorcycle.

NOTE: Use of a commercial degreaser may stain the finish on the engine. Instead, use a mild detergent and water solution.

2. Drain the oil that was in the engine during the storage period. Install a new oil filter and fill the engine with oil as outlined in your owner's manual.
3. Reinstall the battery. Make sure that the vent hose is connected and routed properly. Install the positive terminal before the negative terminal.
4. Lubricate all places as instructed in the lubrication table in the owner's manual.
5. Inflate the tires to the correct pressure.
6. Do the "Inspections Before Riding" as listed in the owner's manual.

Often times it's easier to let these sort of services be done by your dealer. Most dealers in the areas where motorcycle storage is common are set up to properly prepare motorcycles for storage. Whether you do it yourself, or have your dealer do it, we sincerely hope you follow our suggestions. This is the only way that your GS can serve you in the manner it was designed. If your dealer does the service for you, you should be among the first to be back on the road when winter becomes spring.

CAUTION:

Clean the brake disc with alcohol only. This will ensure positive braking.

SPECIFICATIONS

DIMENSIONS AND DRY MASS

Overall length	2 145 mm (57.4 in)
Overall width	820 mm (32.3 in)
Overall height	1 120 mm (47.2 in)
Wheel base	1 420 mm (165.9 in)
Ground clearance	145 mm (5.7 in)
Dry mass	181 kg (399 lbs)

ENGINE

Type	Four-stroke, air cooled, OHV
Number of cylinder	2
Valve lash	0.03-0.08 mm (0.0012-0.0031 in)
Bore	71.0 mm (2.795 in)
Stroke	58.6 mm (2.228 in)
Piston displacement	448 cm ³ (27.3 cu. in)
Compression ratio	9.0 : 1
Carburetor	MIKUNI BS34SS
Air cleaner	Polyurethane foam element
Starter system	Electric
Lubrication system	Wet sump

TRANSMISSION

Clutch	Torque converter
Transmission	2-speed constant mesh
Gearshift pattern	2-up
Primary reduction	1.395 (60/43)
Secondary reduction	0.941 (16/17)
Final reduction	3.090 (34/11)
Gear ratios, Low	2.400 (36/15)
Drive	1.600 (32/20)
Drive system	Shaft drive

CHASSIS

Front suspension	Telescopic, pneumatic/coil spring, oil dampened
Rear suspension	Swinging arm, oil dampened, spring 5-way adjustable
Steering angle	42° (right & left)
Caster	62° 40'
Trail	88 mm
Turning radius	2.3 m
Front brake	Disc brake
Rear brake	Internal expanding
Front tire size	3.80S18 4PR
Rear tire size	4.60S18 4PR

ELECTRICAL

Ignition type	Transistorized with electrical advanced
Ignition timing	15° B.T.D.C. below 1 650 r/min and 40° B.T.D.C. above 4 500 r/min
Spark plug	NGK B8ES or NIPPON DENSO W24ES-U
Battery	12V 43.2 kCh (2Ah)/10HR
Fuse	15 A
Headlight	12V 50/35W
Tail/Brake light	12V 8/23W
Turn signal light	12V 23W
Speedometer light	12V 3.4W
Neutral indicator light	12V 3.4W
L-range indicator light	12V 3.4W
D-range indicator light	12V 3.4W
High beam indicator light	12V 1.7W
Turn signal indicator light	12V 3.4W
Oil pressure indicator light	12V 3.4W
Side stand check light	12V 3.4W
Parking brake check light	12V 3.4W
Fuel meter light	12V 1.7W

CAPACITIES

Fuel tank including reserve	13 L (3.4 US gall)
reserve	2.0 L (2.1 US qt)
Engine oil	2.8 L (3.0 qt)
Front fork oil	187.4 ml (6.33 US oz)
Final gear oil	200-220 ml (6.8-7.4 US oz)

WIRING DIAGRAM

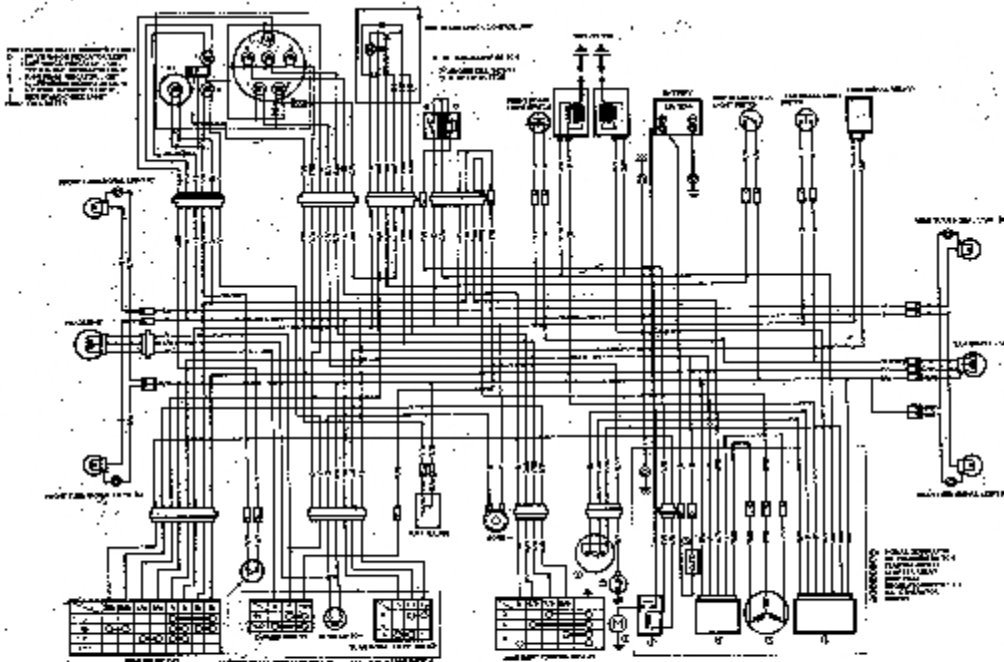

WIRE COLOR

B.....Black
 Bl.....Blue
 Br.....Brown
 G.....Green
 Gr.....Gray
 Lb.....Light blue
 Lg.....Light green
 O.....Orange
 R.....Red
 W.....White
 Y.....Yellow
 B/B.....Black with Blue tracer
 B/Br.....Black with Brown tracer
 B/G.....Black with Green tracer
 B/W.....Black with White tracer

B/Y.....Black with Yellow tracer
 G/Bl.....Green with Blue tracer
 G/R.....Green with Red tracer
 G/W.....Green with White tracer
 G/Y.....Green with Yellow tracer
 Lg/B.....Light green with Black tracer
 O/W.....Orange with White tracer
 W/B.....White with Blue tracer
 W/G.....White with Green tracer
 W/R.....White with Red tracer
 Y/B.....Yellow with Black tracer
 Y/Bl.....Yellow with Blue tracer
 Y/G.....Yellow with Green tracer
 Y/W.....Yellow with White tracer

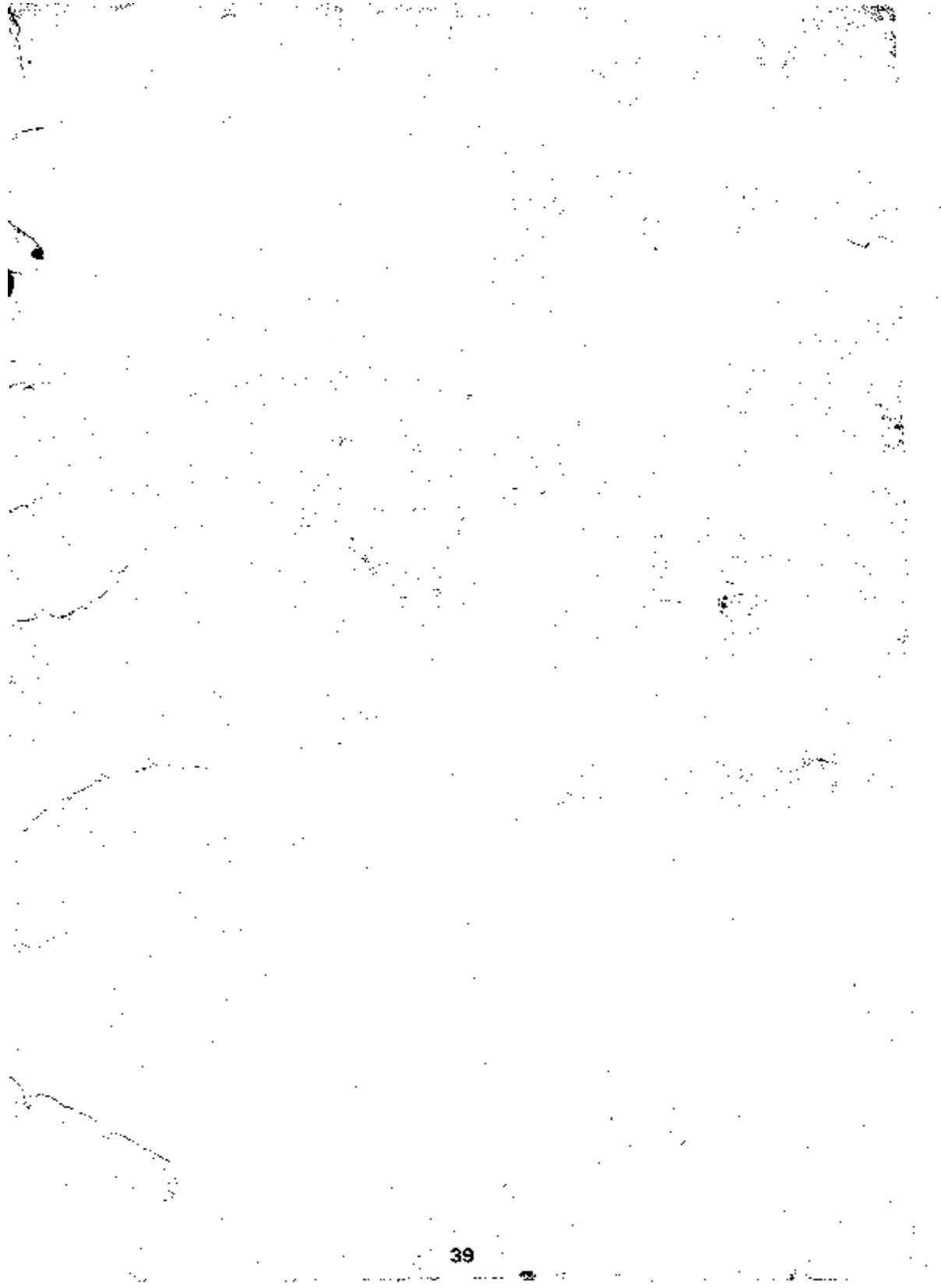

Prepared by

SUZUKI MOTOR CO.,LTD.

Administration Department

Overseas Service Division

July, 1982

Part No. 99011-44521-03A

Printed in Japan

Copying, quoting or reproducing any part of this manual is not permitted without explicit approval by SUZUKI MOTOR CO.,LTD.

All information, illustrations, photographs and specifications contained in this manual are based on the latest product information available at the time of publication. Due to improvements or other changes, there may be some discrepancies in this manual. Suzuki reserves the right to make changes at any time.